

Authorised Distributors:-

ASH & ALAIN INDIA PVT LTD

S-100, F.I.E.E., Okhla Industrial Area, Phase-ii, New Delhi-110020(India)

Tel : 011-43797575 Fax : 011-43797574 E-mail : sales@ashalain.com

OMRON

Linear Sensor Controller

Z4W-D

Easy-to-use Linear Sensor Controller

Offers Two-level Inspection

- PASS and NG discrimination output from linear analog input between 4 and 20 mA
- High-capacity (200 mA at 12 VDC) built-in power supply for sensors
- Built-in gate input for trigger sensor
- 1 to 5 VDC voltage output

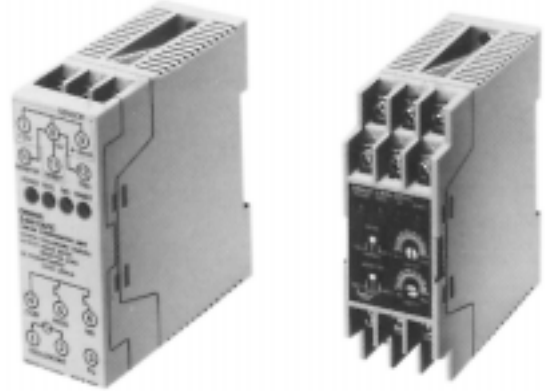

Ordering Information

Part number	Power supply voltage	Inputs	Outputs
Z4W-DD1C	100 to 240 VAC	4- to 20-mA analog, gate input, and inhibit	PASS and NG

Specifications

■ RATINGS

Analog type sensor		Displacement, proximity linear, pressure linear, and other sensors with linear analog outputs between 4 and 20 mA DC
Gate input sensor		NPN transistor output. Trigger on leading edge.
Inhibit input sensor		NPN transistor output. ON: Pass and NG outputs inhibited
Inputs	Analog input (4 to 20 mA)	4 to 20 mA DC (impedance: 100 Ω max.; 30 mA max.)
	Gate input (TRIG)	ON voltage: 0 to 3 V; OFF voltage: 9 to 12 V; short current: 15 mA; maximum voltage: 13.2 V
	Inhibit input (INHIBIT)	
Response time (Total I/O delay)		TRIG mode: 1 ms max. NORMAL or OFF-DELAY: 5 ms max.
Discrimination range		Reference range: 4 to 20 mA (FS) Tolerance: ±1.25% to ±25% FS
Internal hysteresis		1% FS max. (total temperature range)
Outputs	Discrimination outputs (PASS and NG)	NPN open collector, 30 VDC, 100 mA max.
	Monitor output (MONITOR)	1 to 5 VDC voltage output (tolerance, input value, and center correction are switch-settable)
Indicators		POWER, PASS: Green NG, INHIBIT: Red
Timer		40±8 ms (OFF-DELAY mode)
Power-on reset time		400 ms min., 3.5 sec max.

■ CHARACTERISTICS

Power supply voltage	100 to 240 VAC±10%, 50/60 Hz	
Power consumption	15 VA max.	
Sensor power supply	200 mA max. at 12 VDC ±10% (short-circuit protection provided)	
Noise immunity	±1,500 V peak-to-peak, max.; noise pulse width: 1 ms	
Vibration resistance	Destruction: 10 to 150 Hz (0.75-mm double amplitude, 7G max.) for 8 min each in X, Y, and Z directions	
Shock resistance	Destruction: 30G for 3 times each in X, Y, and Z directions	
Momentary power interruption	20 ms max. withstand time	
Ambient temperature	Operating: -10° to 55°C (14° to 131°F), with no icing	
Ambient humidity	35% to 85%, with no icing	
Weight	140 g (4.9 oz.), with terminal cover	
Approvals	UL	E41515
	CSA	LR45951-177

Nomenclature

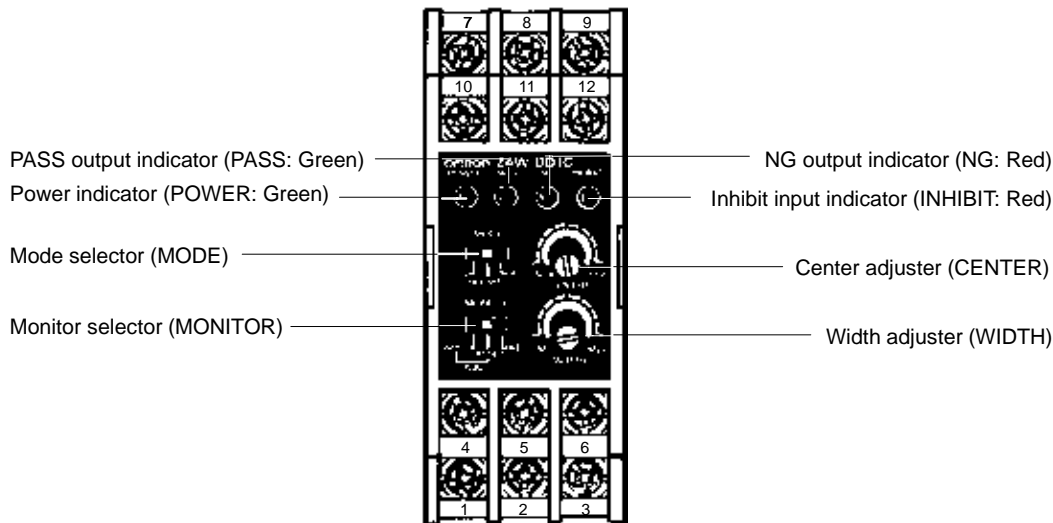

Classification	Functions
Power indicator (POWER: green)	Lit when power is ON and the Sensor power supply output is enabled. Not lit when power is OFF, or the Sensor power supply output is short-circuited (the +12 V and 0 V terminals are short-circuited).
PASS output indicator (PASS: green)	Lit when the PASS signal (a discrimination output) is ON.
NG output indicator (NG: red)	Lit when the NG signal (a discrimination output) is ON.
Inhibit input indicator (INHIBIT: red)	Lit when an INHIBIT signal (an inhibit input at terminal 11) is accepted. The PASS and NG signals will be turned OFF.
Mode selector (MODE)	TRIG: A discrimination operation is enabled when the gate input is ON (at the rising edge). The result is held until the next gate input is received. No discriminating operation is enabled when the INHIBIT signal is ON, even if the TRIG signal is ON. NORMAL: Discrimination output from analog output signals of the Linear Sensor is available. No discrimination output is enabled when the INHIBIT signal is ON. The Z4W-D resumes operation 5 ms (max.) after the INHIBIT signal turns OFF. OFF-D: Discrimination output from analog output signals of the Linear Sensor is available. The PASS signal can be held for approximately 40 ms in OFF-delay operation. Even if the PROHIBIT signal is ON, the PASS signal is held when the OFF-delay function is enabled. No discrimination output is enabled when the INHIBIT input is ON. The Z4W-D resumes operation 5 ms (max.) after the INHIBIT signal turns OFF.
Center adjuster (CENTER)	A value of 4 to 20 mA can be set on the adjuster (a two-turn variable resistor) as the standard value for discrimination.

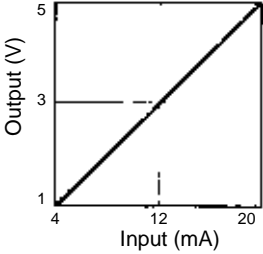
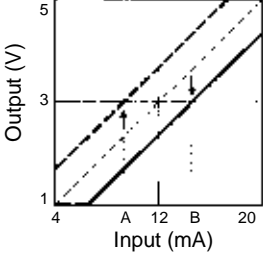
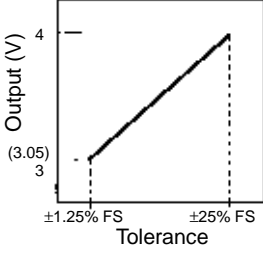
Classification	Functions
<p>Monitor selector (MONITOR)</p>	<p>RUN: For INPUT or OFFSET signals. Set to this position when the Z4W-D is in operation.</p> <p>INPUT: An input signal of 4 to 20 mA is converted into a 1 to 5 V signal and output to the monitor terminal.</p>  <p>OFFSET: An input signal of 4 to 20 mA is converted into a 1 to 5 V signal and output to the monitor terminal. With the dial turned to the OFFSET position, the standard value set is converted into a 3-V signal.</p> <p> - - - - - Monitor output with standard value A _____ Monitor output with standard value B </p>  <p>WIDTH: The tolerance value set is converted into an electrical signal and output to the monitor terminal.</p> <p>The relationship between the monitor output voltage and tolerance is as follows:</p> <p>V_x (V) = Monitor output voltage $\pm W_o$ (% FS) = Tolerance $V_x = 3 + W_o \times 1/25$</p> 
<p>Width adjuster (WIDTH)</p>	<p>The tolerance value can be set within the range of $\pm 25\%$ FS (using a two-turn variable resistor and indicator).</p>

Operation

■ MAIN FUNCTIONS OF THE LINEAR SENSOR CONTROLLER

When used in conjunction with a Displacement Sensor (or any other Linear Sensor that has a DC output of 4 to 20 mA) in product discrimination operations, the Linear Sensor Controller differentiates between acceptable products (products within the permissible range of dimensions, as indicated by PASS) and defective products (products outside the permissible range of dimensions, as indicated by NG).

Use the CENTER and WIDTH adjusters on the front panel of the Z4W-D to set the permissible range of dimensions. When a Linear Sensor or Displacement Sensor is used in combination with the Z4W-D Controller to test product dimensions, the permissible range of dimensions is defined as the standard value plus the tolerance to standard value minus the tolerance. Use the two adjusters to set the standard value and tolerance (for the given product).

For synchronization, a Photoelectric Sensor (Gate Sensor) can be used. The Z4W-D Controller can supply power to the Linear Sensor and the Gate Sensor (200 mA max. at 12 VDC).

On the front panel of the Z4W-D Controller, check the voltage of the monitor terminals with a Panel Meter or a multimeter to monitor and confirm the standard value and tolerance set by the two adjusters.

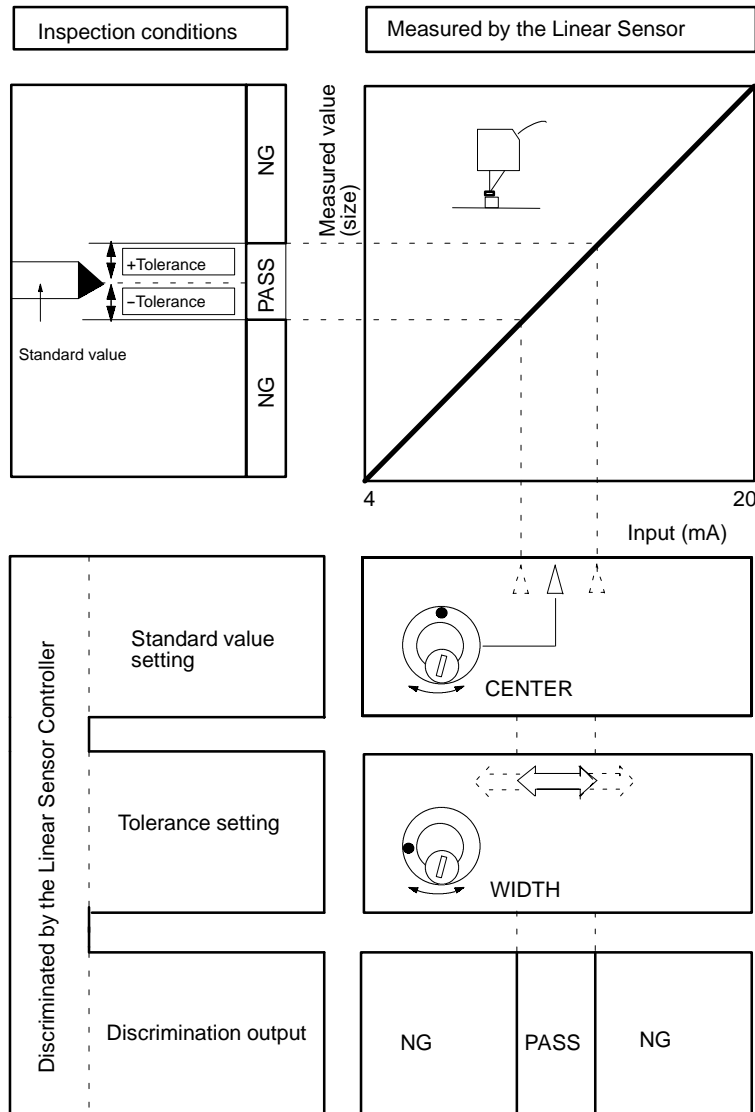

■ TYPICAL APPLICATIONS

Checking Part Sizes

The size of molded parts is measured by the Displacement Sensor synchronized with the Fiber-Optic Sensor to produce a PASS or NG output. To use a diffuse type sensor, select the mode in which the Photoelectric Sensor is ON when a light input signal is detected.

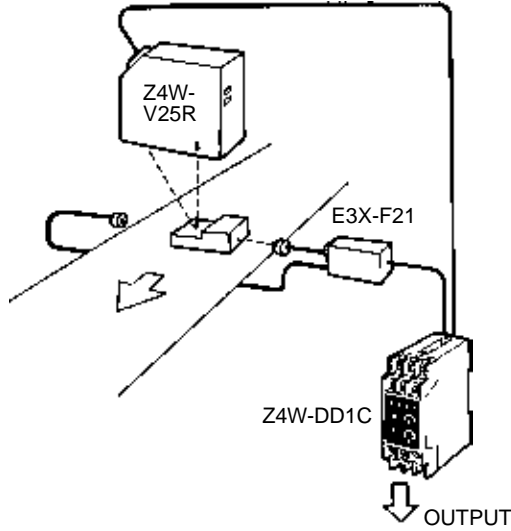

Z4W-DD1C Mode Selector Switch	
Mode selector switch (MODE):	TRIG
Monitor selector switch (MONITOR):	RUN

Connection

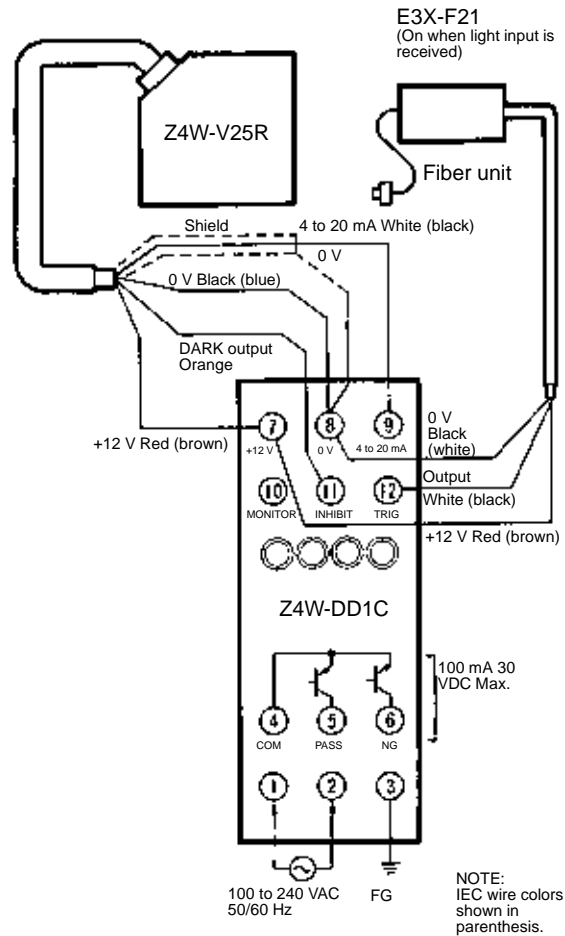

Timing Chart

When no object is in front of the Displacement Sensor in the DARK state, both the PASS output and NG output of the Z4W-DD1C, synchronized by the TRIG input, are OFF. However, by disconnecting the DARK output of the Displacement Sensor from terminal 11 (INHIBIT) of the Z4W-DD1C, the NG output of the Z4W-DD1C in the DARK state turns ON.

If the user does not want the Z4W-DD1C output signals to be retained because the Z4W-DD1C is connected to a PLC or a Counter, refer to the application example under the heading *Checking the Packing of Bottle Tops*.

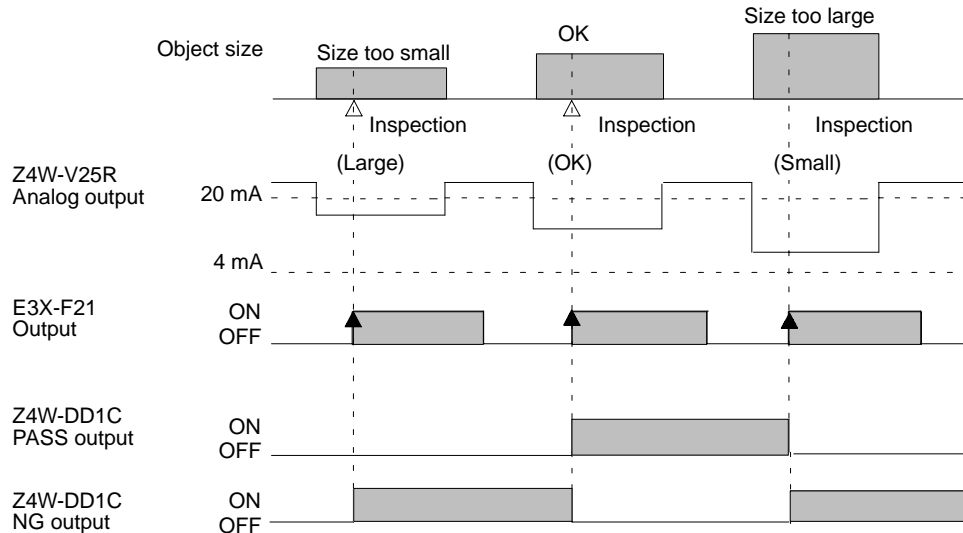

Checking Plate Flatness

While the plates are measured by the Displacement Sensor, the NG signal is output by the Linear Sensor Controller whenever the thickness of the plates deviates outside the permissible range.

When the Fiber-Optic Sensor is connected to the INHIBIT terminal of the Z4W-DD1C, the Fiber-Optic Sensor's INHIBIT signal is ON when an object is detected and OFF when no object is detected. The Z4W-DD1C operates only when an object is detected.

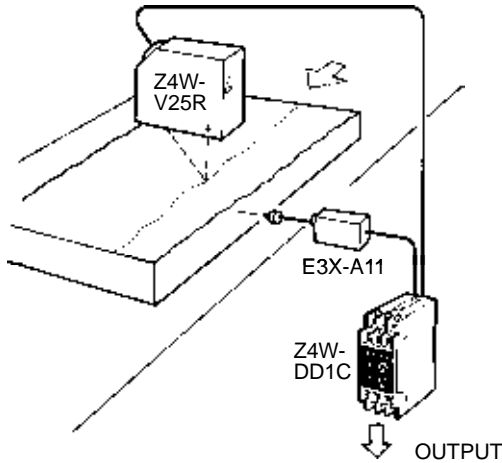

Z4W-DD1C Mode Selector Switch	
Mode selector switch (MODE):	NORMAL or OFF-D
Monitor selector switch (MONITOR):	RUN

Connection

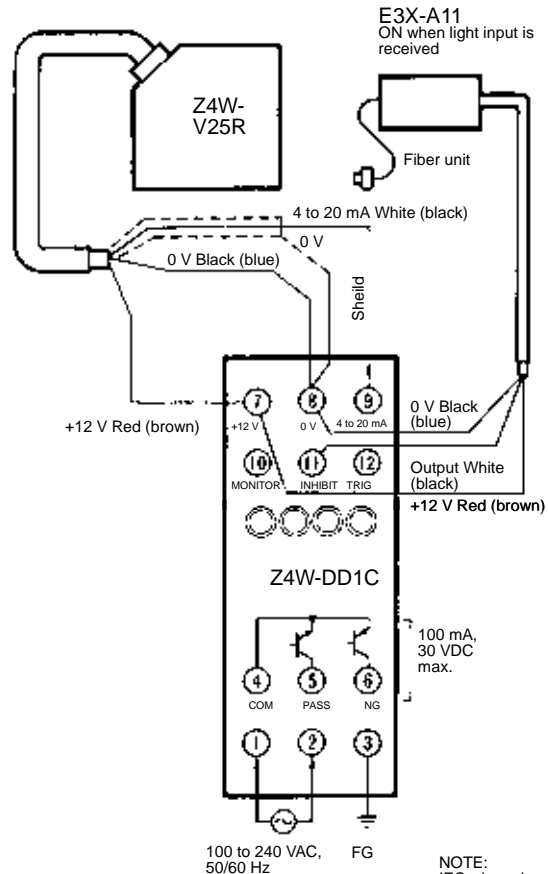

NOTE:
IEC wire colors shown
in parenthesis.

Timing Chart

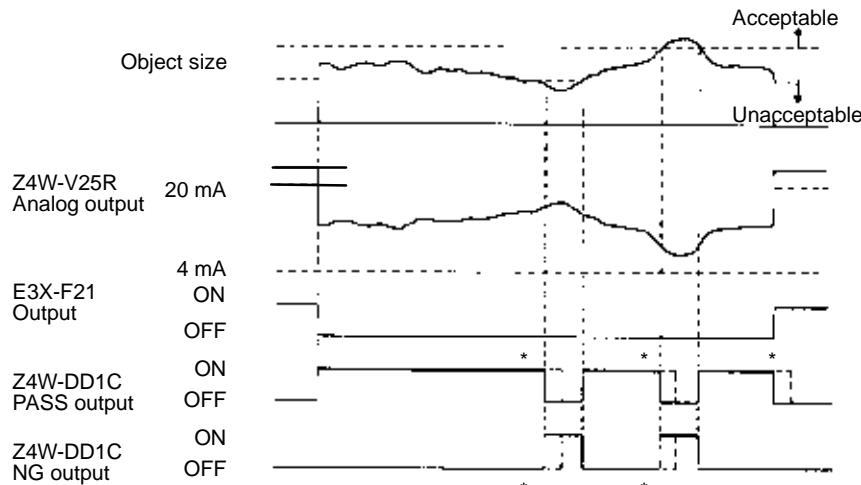

Note: When the Z4W-DD1C selector switch is set to OFF-D, a PASS output OFF-delay of approximately 40 ms results, illustrated by asterisks in the timing chart above.

Checking the Packing inside Bottle Tops

In this application example, the bottle tops are measured by the Displacement Sensor. By using the one-shot timer function of the S3D2 Sensor Controller in combination with the Fiber-Optic Sensor, the Z4W-DD1C operates only when a bottle top is within the detection spot of the Displacement Sensor. With a Counter or PLC connected to the Linear Sensor Controller, the operation of counting is simple, since only one pulse signal (PASS or NG) is output for each bottle top. When using a diffuse-type Fiber, select the mode in which the Photoelectric Sensor is ON when a light input signal is detected.

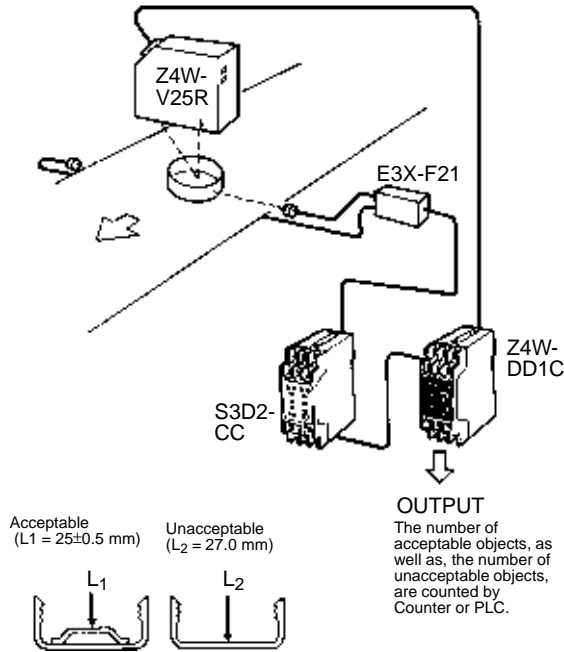

Z4W-DD1C Mode Selector Switch	
Mode selector switch (MODE)	NORMAL or OFF-D
Monitor selector switch (MONITOR)	RUN

S3D2-CC Mode Selector Switch		
IN1	NORM	
MODE	OR	
IN2	NORM	IN2 can be at any position since it is not used.
	SYNC	
TIMER	ON	
RANGE	0.1 s	
TIMER MODE	O.S	

Connection

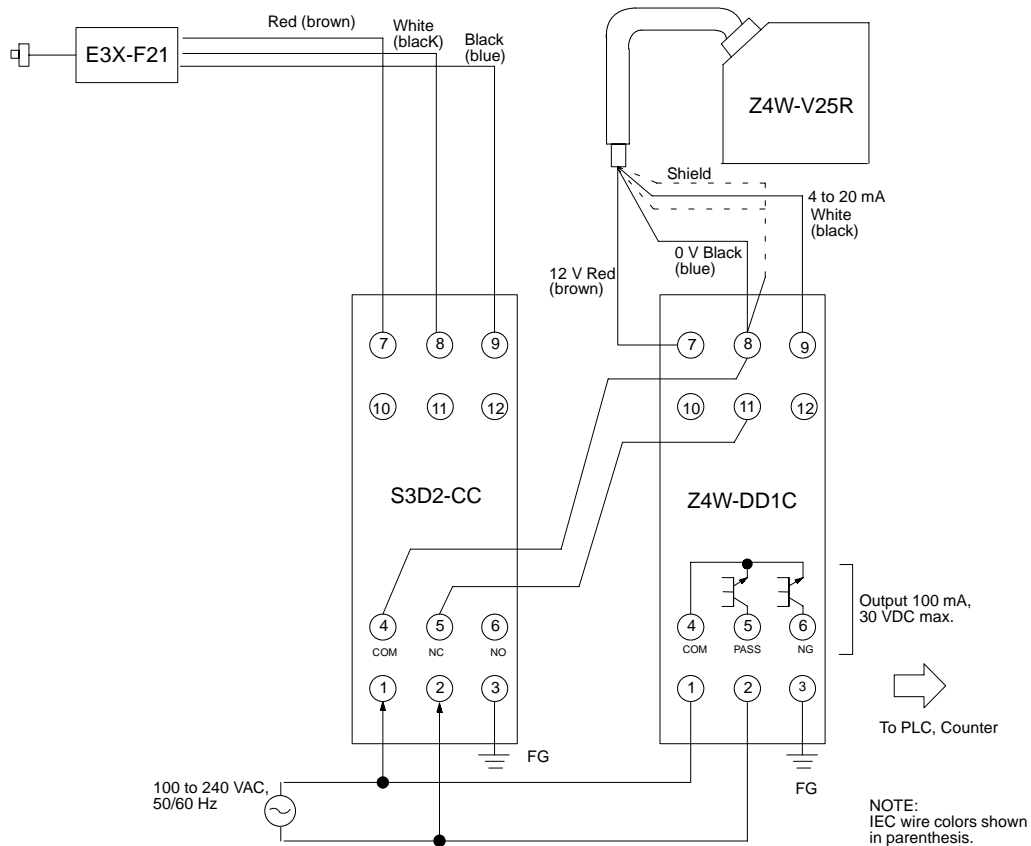

Timing Chart

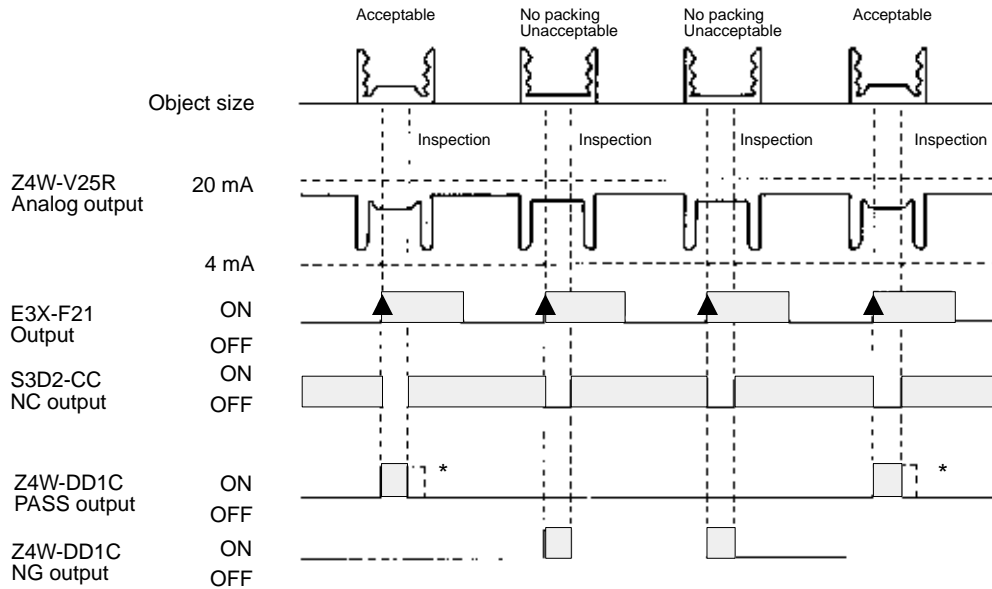

Note: When the Z4W-DD1C Mode Selector Switch is set to the OFF-D position, an output OFF-delay of approximately 40 ms results, illustrated by asterisks in the timing chart above.

SENSORS DRIVEN BY SYNCHRONOUS OR INHIBIT INPUTS

Sensors with Relay Outputs

The Z4W-D responds instantly to an input signal. When connecting a relay output type sensor to the gate input of the Z4W-D; noise caused by contact bouncing, relay chattering, or the snap-action switch may be mistaken as an input signal to the Z4W-D.

Incompatible Sensors

The Linear Sensor Controller cannot be connected to a Gate Sensor that does not have a NPN open-collector output. Because of this, Gate Sensors that are the two-wire type, voltage output type, or AC type cannot be connected to the Linear Sensor Controller.

Discrimination Output

If a noise-generating component such as an inductive load is connected to the Linear Sensor Controller, connect a surge absorbing element (a diode, for example) with the load.

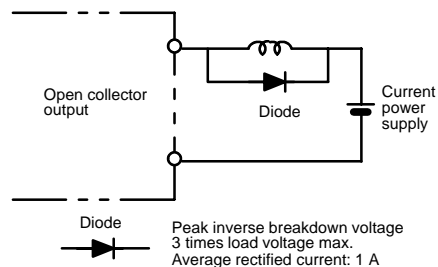

OPERATIONS

Sensor Connection

Before connecting any Sensors to the Z4W-DD1C, refer to the instruction manuals for the Sensor models you will use. Also, within this data sheet, refer to the connection examples found in both the Applications section and the Installation section.

Do not switch power ON when connecting the sensors to the Z4W-DD1C. If power is required for the purpose of adjustment (such as, for the axis adjustment of a Sensor), make sure nothing is connected to the output terminals, terminals 4, 5, or 6 (PASS and NG), of the Z4W-DD1C before power is turned on.

Setting Standard Value

1. To set the Linear Sensor Controller with the desired standard value, adjust the Linear Sensor so that its output value will be as large as the desired standard value. To discriminate between objects with the Displacement Sensor, for example,

prepare a standard-sized product to be measured by the Sensor first.

2. Set the Z4W-DD1C Mode Selector Switch to the NORMAL position.
3. Turn the WIDTH controller counterclockwise to the MIN position.
4. Turn the CENTER controller clockwise or counterclockwise and set the controller to the position where the PASS LED is lit. If the PASS LED is lit for a wide range of positions, set the controller in the middle of the range. If the PASS LED does not light with the CENTER controller in any position, turn the WIDTH controller clockwise slightly.

Setting the Tolerance

1. To set the Linear Sensor Controller with the desired tolerance, adjust the Linear Sensor so that its output value will be as large as the desired threshold value (i.e., the standard value plus the tolerance or the standard value minus the tolerance). In operation with the Displacement Sensor for example, an object of threshold dimensions must be measured by the Sensor. Set the Z4W-DD1C Mode Selector Switch to the NORMAL position.

ured by the Sensor. Set the Z4W-DD1C Mode Selector Switch to the NORMAL position.

2. Set the Z4W-DD1C Mode Selector Switch to the NORMAL position.
3. Turn the WIDTH controller clockwise slowly from the MIN position. Set the controller to the position where the PASS LED is lit and the NG LED is OFF.

Setting the Mode Selector Switch

The Mode Selector Switch is set to RUN to operate the Z4W-DD1C (refer to the table). After selecting RUN, wire the SYSMAC BUS Wired Remote Output Blocks (terminals 4, 5, and 6 (PASS/NG)).

Switch	Position of the selector switch	
Mode selector switch	TRIG	In this position, if the Gate Sensor is connected to the Linear Sensor Controller via terminal 12 (TRIG), the discrimination operation is available every time the output of the Gate Sensor is ON. The Linear Sensor Controller holds the result until the next discrimination operation.
	NORMAL	This position can be selected if the Gate Sensor is not used. This position can be selected if the Gate Sensor is connected to the Linear Sensor Controller via terminal 11 (INHIBIT) and the Gate Sensor is set so that it will have no output when there is no object. While there is no object, the discrimination output is OFF. With a counter connected to the Linear Sensor Controller, counting is simple.
	OFF-D	There is no difference between operation in the NORMAL position and the OFF-D position except the OFF-delay function. In this position, an OFF-delay of 40 ms results. If the PLC is connected to the Linear Sensor Controller with this position selected, only the PASS output is available.
Monitor selector switch	RUN (INPUT or OFFSET)	

Note: In Monitor Modes, MONITOR output by measuring the monitor output voltage with a multimeter or Panel Meter. Both the standard values and the tolerance values set can be monitored. Refer to the Nomenclature section in this data sheet.

Dimensions

Unit: mm (inch)

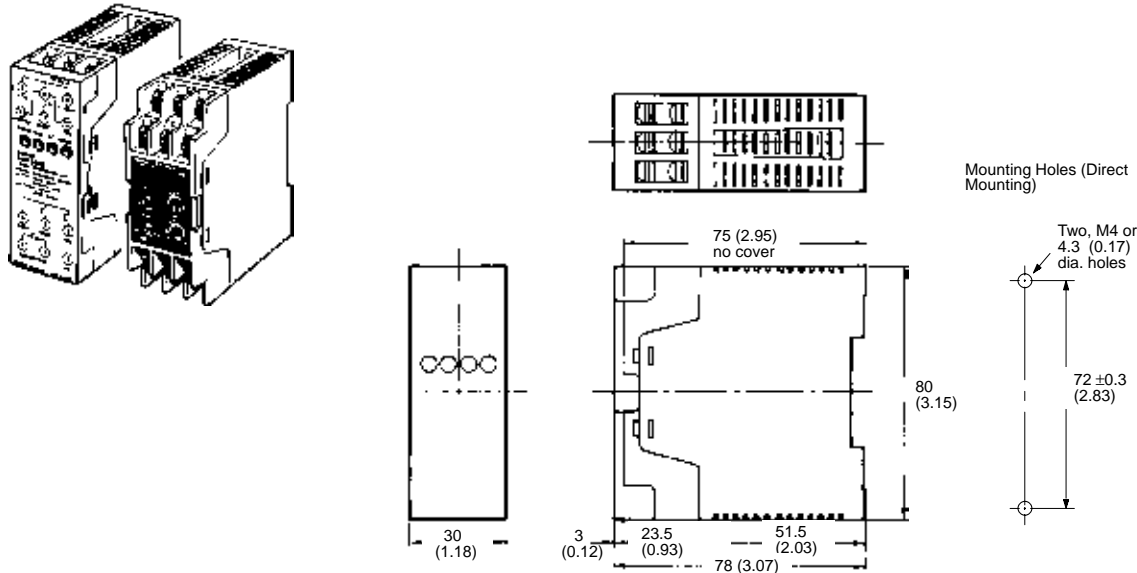

Installation

CONNECTIONS

A Linear Sensor model with a current output of 4 to 20 mA (such as, Z4M Laser Displacement Sensor, E3XA, or E3SA Analog Photoelectric Sensor) can be connected to linear input terminal 9 (4 to 20 mA).

Connection with a Z4W-V Displacement Sensor

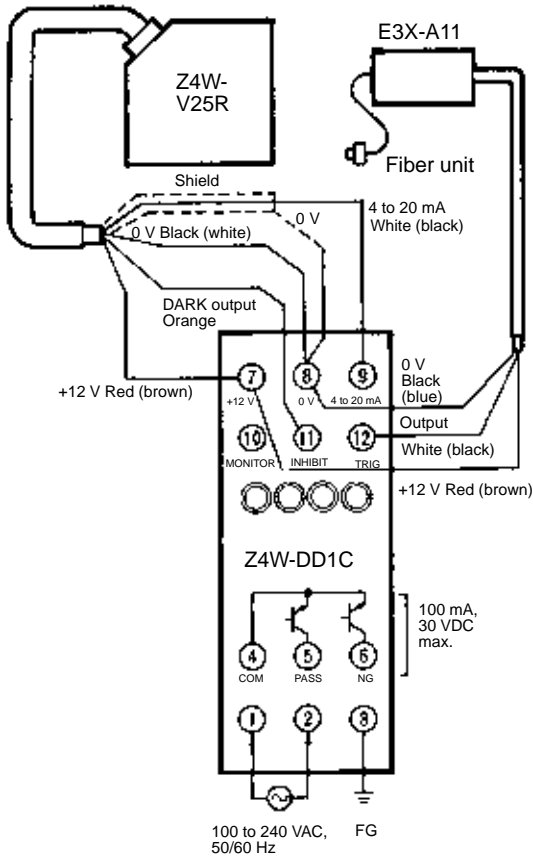

NOTE:
IEC wire colors shown
in parenthesis.

Connection with a Z4W-A Displacement Sensor

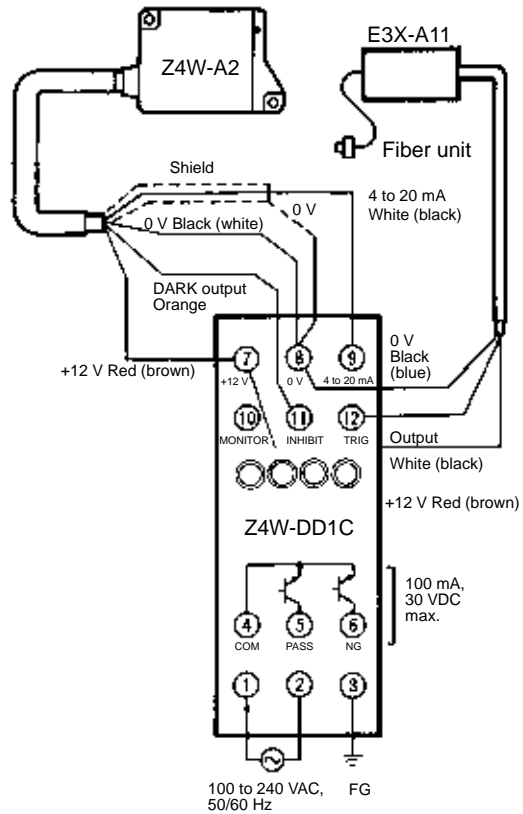

NOTE:
IEC wire colors shown
in parenthesis.

Connection with a 3Z4M-J10/-J12 Displacement Sensor

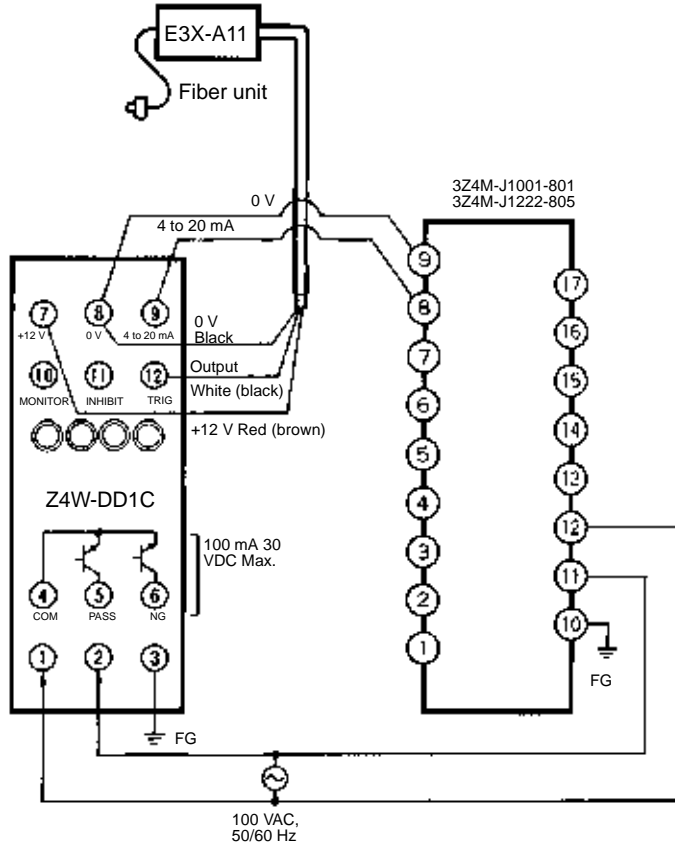

NOTE:
IEC wire colors
shown in
parenthesis.

Connection with a E8CA or E8AA Pressure Linear Sensor

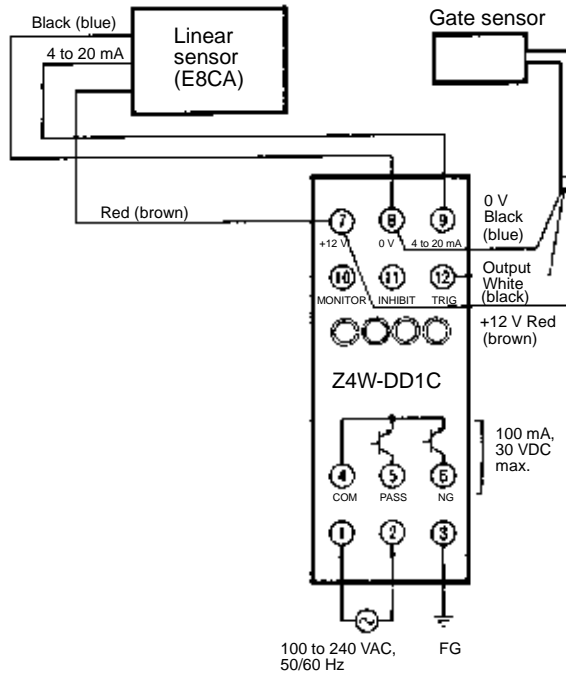

NOTE:
IEC wire colors
shown in
parenthesis.

Connection with a E2CA Proximity Linear Sensor

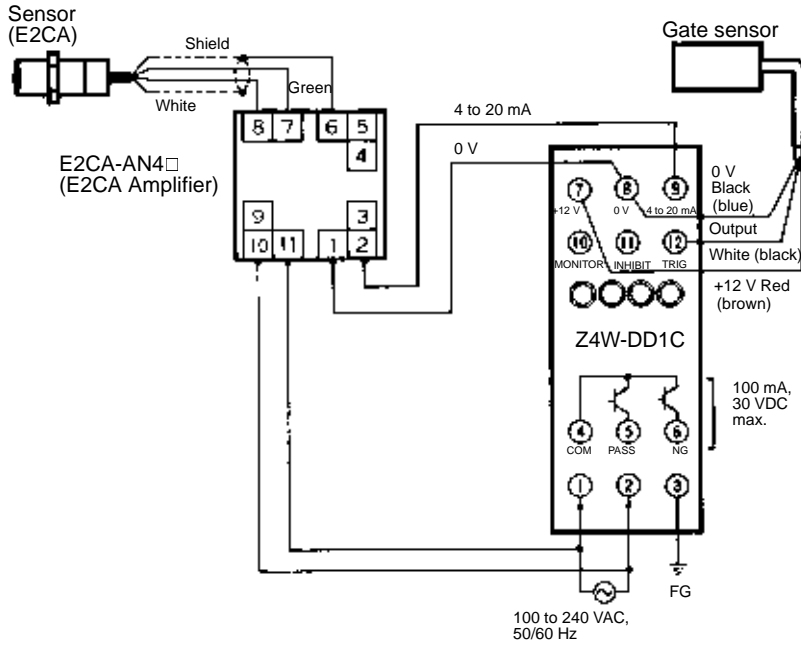

I/O CIRCUITS

Input Circuit

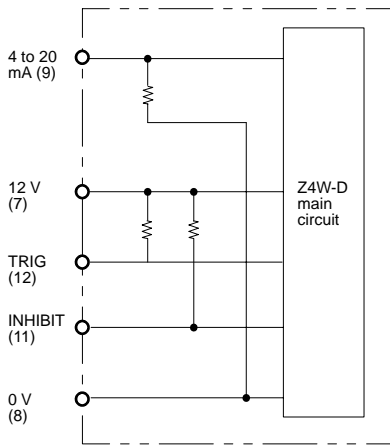

Output Circuit

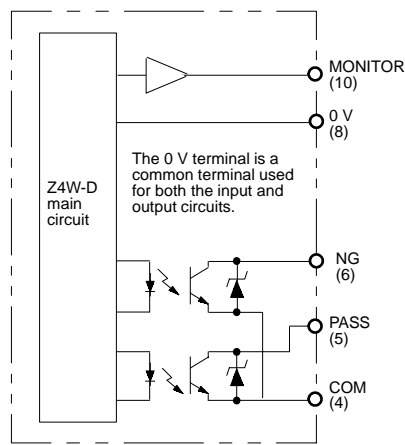

Connection of Loads

Loads are connected to the collector.

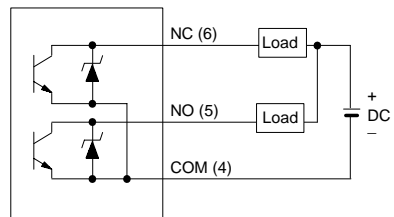

Precautions

■ OPERATION AND WIRING

1. For the correct connection of the power supply to the power supply terminal make sure that the supply voltage is 100 to 240 VAC $\pm 10\%$.
2. When using the Z4W-D in an environment with excess noise, ground the FG terminal (the ground terminal) with a ground resistance of 100 Ω max.
3. Ground FG independently, not with the ground lines of other equipment. If not grounded independently, noise interference could cause malfunction. Do not connect FG to the building substructure.

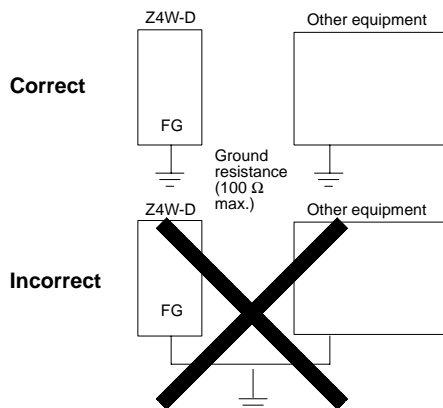

4. Wire the input and output lines of the Z4W-D separately to avoid malfunction due to noise.
5. Install the Z4W-D at least 20 cm away from power lines carrying large currents (such as, power lines supplying motors).

■ CLOSE PROXIMITY INSTALLATION

Z4W-D Linear Sensor Controllers can be installed in close proximity with each other. Allow a minimum gap of 10 mm between the Controllers. You may use a PFP-M End Plate to ensure that a gap of 10 mm is attained.

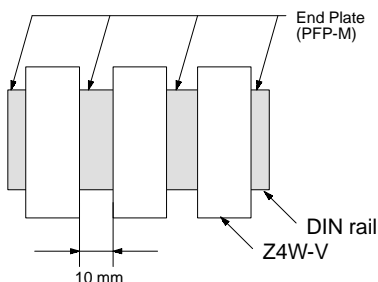

■ OUTPUT

If a noise-generating component (such as, an inductive load) is connected to the Linear Sensor Controller, connect a surge absorbing element (a diode, for example) with the load. Connect the cathode of the diode to the positive terminal of the power supply.

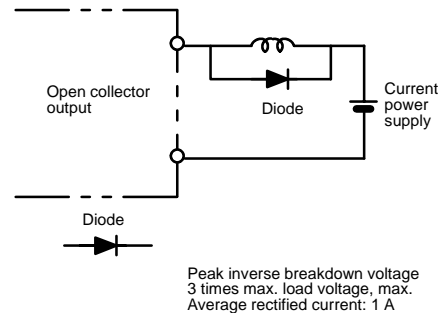

■ POWER SUPPLY WHEN OPERATING WITH SENSOR

The power supply reset time of the Z4W-D is 0.4 seconds. Power can be supplied to the Sensor through the sensor power supply terminals of the Z4W-D. In this case, however, the response time of the sensor connected should be 0.4 seconds or less. Use of a sensor with a response time larger than 0.4 seconds results in the sensor malfunctioning at power ON.

If power is supplied to the Sensor through an independent power supply, first turn ON Sensor power before turning ON the Z4W-D power. Turning ON the Z4W-D power first would produce a momentary output.

When power is applied to the Z4W-D, a delay of 0.4 to 3.5 seconds occurs before the Z4W-D becomes operational.

The Z4W-D will have a momentary output when power is turned OFF.

■ MOUNTING WITHIN A CONTROL PANEL

Take heat radiation into consideration when mounting the Z4W-D in a control panel.

Sensor Power Supply (max load current)

Refer to the graph below if Controllers are to be installed in close proximity with each other.

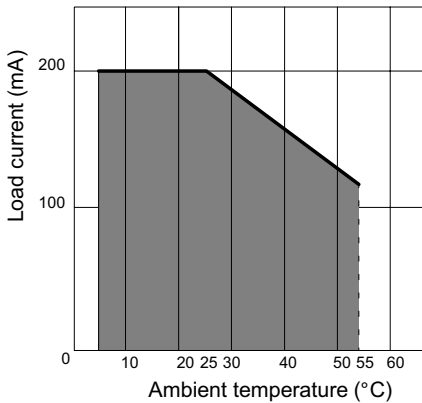

NOTE: DIMENSIONS SHOWN ARE IN MILLIMETERS. To convert millimeters to inches divide by 25.4.

OMRON**OMRON ELECTRONICS, INC.**

One East Commerce Drive
Schaumburg, IL 60173

1-800-55-OMRON**OMRON CANADA, INC.**

885 Milner Avenue
Scarborough, Ontario M1B 5V8

416-286-6465

Cat. No. GC MSEN3

2/98

Specifications subject to change without notice.

Printed in U.S.A.

**ASH & ALAIN****Authorised Distributors:-****ASH & ALAIN INDIA PVT LTD**

S-100, F.I.E.E., Okhla Industrial Area, Phase-ii, New Delhi-110020(India)

Tel : 011-43797575 Fax : 011-43797574 E-mail : sales@ashalain.com